

HATFIELD BOROUGH

Driveway Permit Information

PROCEDURES FOR DRIVEWAY PERMITS

After appropriate driveway permit fees are paid, the driveway permit is reviewed by the Borough Engineer. This is not done overnight. The Borough Engineer, at his convenience, will meet the applicant at the site, provided the applicant's driveway is staked out properly. If the driveway is staked out, the applicant must meet the Borough Engineer at the driveway site in case the Borough Engineer has a question on the sketch submitted with each driveway permit.

Appointments must be made directly with the Borough Engineer, Bursich Associates, Inc. (610) 323-4040.

- ZONING REVIEW MAY APPLY !!!

After inspecting the driveway, the Borough Engineer may determine that some special conditions may be needed, which shall be added to the driveway permit. He will then have the Borough Secretary type the special conditions on the driveway permit, and if the driveway meets specifications, the Borough Engineer will then sign the permit. Again, the Borough Engineer will inspect the driveway at his convenience and several days should be allowed for processing of the forms.

General Regulations:

1. Paved driveways shall consist of 2" depth bituminous wearing course on 4" depth 2A modified stone base.
2. The property owner is responsible for obtaining any other permits which may be required and complying with any other state / federal government regulations.
3. The slope of a driveway shall not exceed twelve (12) percent. The first twenty feet from the curbline shall not exceed five (5) percent.
4. A driveway serving a single dwelling unit shall have a minimum width of ten (10) feet. A common driveway, serving up to four (4) dwelling units shall have a minimum width of sixteen (16) feet.
5. A driveway serving a single dwelling unit shall be located as far from street intersections as reasonably possible but no less than fifty (50) feet from the nearest street intersection.
6. The construction of all driveways will be subject to the inspection and approval of the Borough. The Borough shall be notified a minimum of 48 hours in advance of construction.
7. Concrete aprons for driveways shall be six (6) inches thick and reinforced with wire, six by six (inches), number 9 wire. The wire shall be installed no closer than ½ inch from the top or bottom surfaces of the apron.
8. Curbing:
 - a) The permit may require the installation of curbing wherever it is required to control access or drainage, or both. All curbing must be permanent curbing.
 - b) Where property abutting the road right of way line could be used as a parking area, the permit may require curbing, permanent guiderail, or fencing to be constructed along the right of way line in order to prohibit vehicle encroachment upon the sidewalk or shoulder area.
 - c) When curb exists adjacent to the proposed driveway, the line and grade of the existing curb shall be matched, unless otherwise authorized by the permit.

Borough of Hatfield

37 N. Market St., PO Box 190
Hatfield, PA 19440
Ph: 215-855-0781 F: 215-855-2075

For Borough Use Only:

Permit: _____
Tax Map Parcel: _____
Block: _____ Unit: _____
Approved by: _____ Date: _____

Zoning Permit Application

Please type or print all information

Site Street Address: _____

Applicant: _____ Property Owner: _____

Mailing Address: _____ Mailing Address: _____

City, State, Zip: _____ City, State, Zip: _____

Phone Number (H): _____ Phone Number (H): _____

Phone Number (W): _____ Phone Number (W): _____

Current use of Property: _____

Proposed use (if different): _____

Permit Type

New Building Length: _____ Width: _____ Height: _____

Addition Length: _____ Width: _____ Height: _____

Shed Length: _____ Width: _____ Height: _____

Fence Wood Vinyl Chain Link Length: _____ Height: _____

Pool Above-ground In-ground

Deck Square Feet: _____ Height Above Ground: _____

Other: _____

Site Plan

The site plan on page 2 of this application must be completed for the permit to be processed.

Applicants Signature: _____ Date: _____

Site Plan

A site plan must be provided for all applications. If you already have a site or plot plan, you may submit that plan instead of using the site plan below as long as all required information is included. Please be sure to include the following information on the plan.

- Property dimensions,
- All existing buildings, decks, sheds, pools, fences and driveways with dimensions,
- All proposed construction with dimensions,
- Distances from all property lines to the proposed construction,
- Distances between existing buildings and proposed construction.

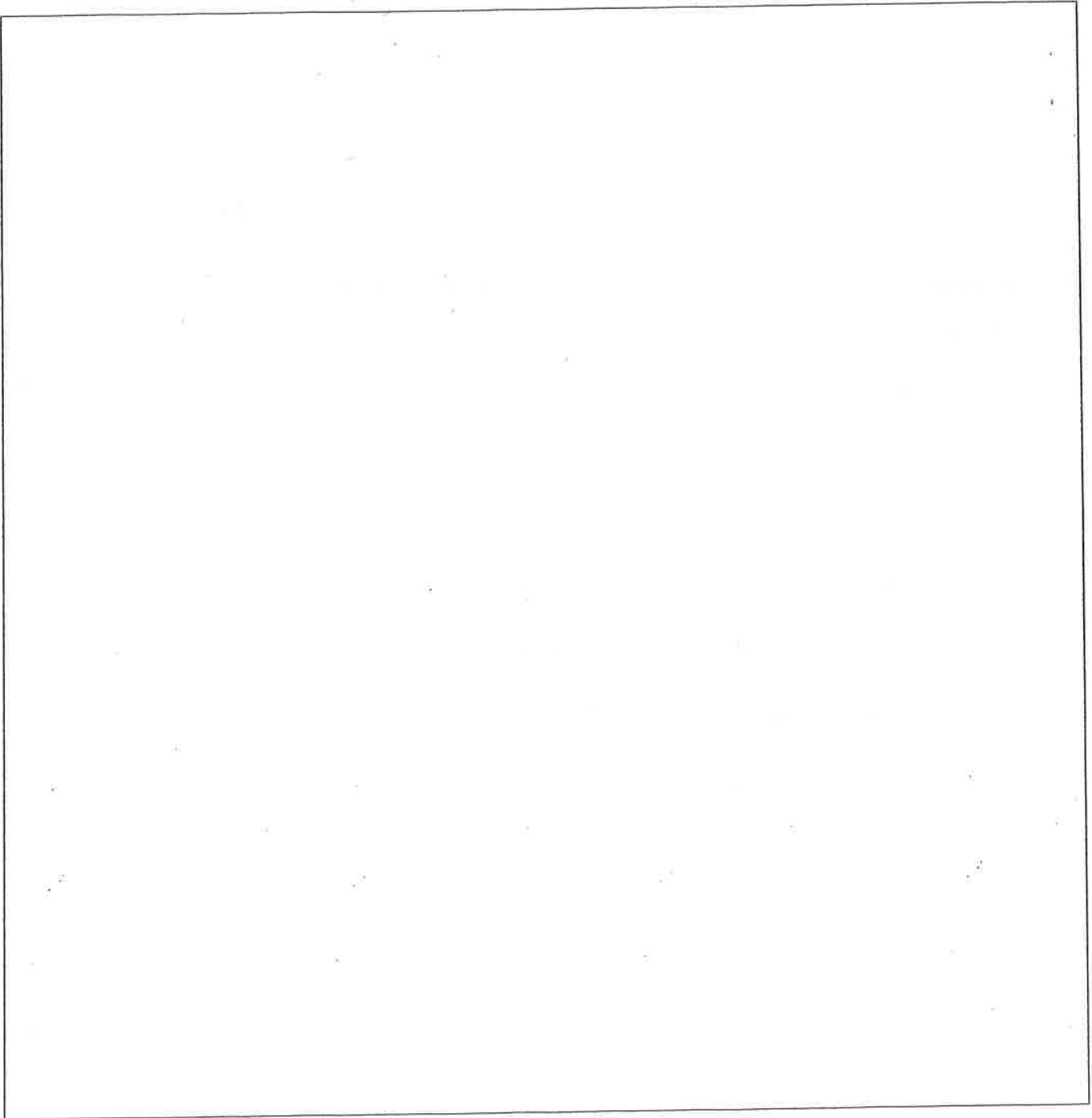

HATFIELD BOROUGH
MONTGOMERY COUNTY
DRIVEWAY PERMIT APPLICATION

INFORMATION SHEET FOR DRIVEWAY PERMITS: Please fill out all information below and attach appended documents. There shall be appended to each application a drawing or plan showing the outlines of the property affected with existing improvements thereon, existing drains, culverts, footwalks, drives or driveways with the proposed drain, culvert, footwalk, drive or driveway proposed to be added, and the relationship of the foregoing to the Borough Street.

Contact the **BOROUGH ENGINEER** at (610) 323-4040 to make an appointment for inspection. After this sheet is filled out and handed in along with supporting documents and inspection by the Borough Engineer, a Permit will be issued.

DRIVEWAY APPLICATION COST \$150.00

The Driveway Permit is good for one (1) year of date of issuance. If an extension is needed, the Borough must be notified. **DRIVEWAY PERMITS MUST BE SECURED BEFORE APPLYING FOR A BUILDING PERMIT.**

1. Owner _____ Phone No. _____
Address _____
2. Contractor _____ Phone No. _____
Address _____
3. Engineer _____ Phone No. _____
Address _____
4. Location of proposed Driveway _____
5. Length of Proposed Driveway _____ Width _____
6. Driveway abuts on what road _____
7. Minimum curb radius of driveway _____
8. Maximum curb radius of driveway _____
9. Does curbing exist on street abutting driveway? _____
10. Sizes and types of pipes and construction of the dip section _____

11. Type of surfacing materials proposed _____
12. Time of proposed work _____

13. Driveway permit and supporting documents must be brought into the Borough Office for issuance and approvals.

I hereby make application for a permit to construct a driveway in accordance with specifications and plans herewith submitted subject to all the requirements of the Borough Ordinances and the laws of the Commonwealth of Pennsylvania.

APPLICANT SIGNATURE

DATE

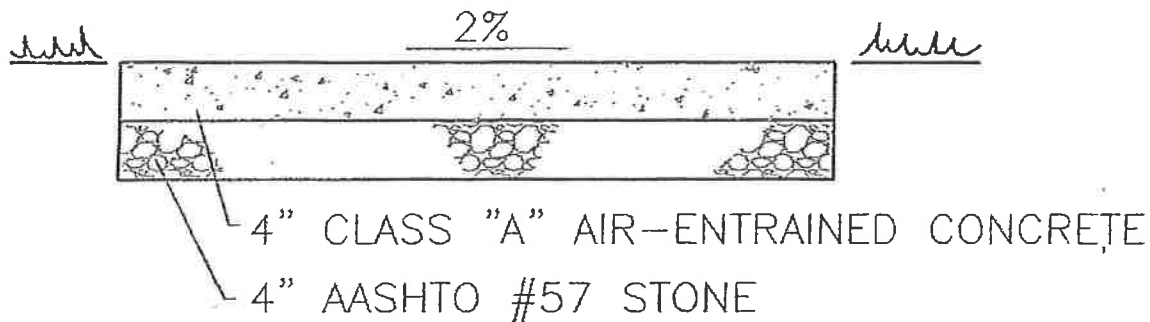

SIDEWALK DETAIL NOTES:

1. SIDEWALKS AT DRIVEWAYS SHALL BE 6" THICK CONCRETE WITH 6"x6" - NO. 9 WIRE (2 LAYERS, 2" APART. $\frac{1}{2}$ " FROM SURFACE.)
2. $\frac{1}{2}$ " BIT. EXP. JOINT AT 20' O.C.
3. CONSTRUCTION JOINT AT 5' O.C.

HATFIELD BOROUGH
SIDEWALK / DRIVEWAY APRON
DETAIL

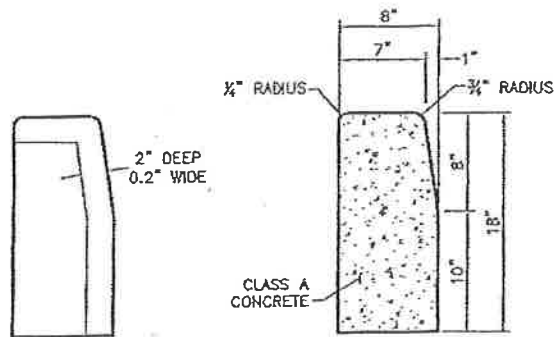

DETAIL A
CONTRACTION JOINT
NO SCALE

TYPICAL
CROSS SECTION
NO SCALE

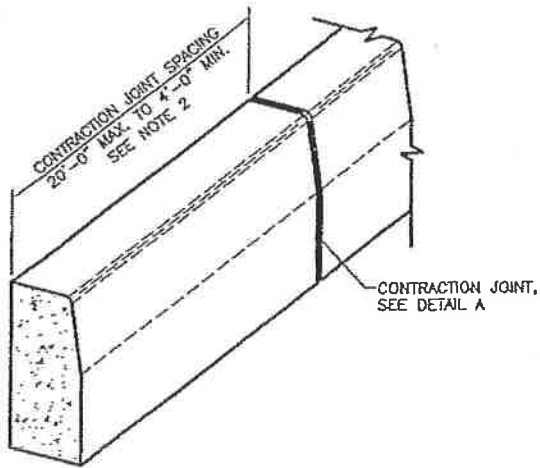

NOTES

1. PROVIDE MATERIALS AND CONSTRUCTION MEETING THE REQUIREMENTS OF PUBLICATION 408, SECTION 630 FOR PLAIN CEMENT CONCRETE CURB AND DEPRESSED CURB, SECTION 640 FOR PLAIN CEMENT CONCRETE GUTTER AND SECTION 641 FOR PLAIN CEMENT CONCRETE CURB GUTTER.
2. SPACE CONTRACTION JOINTS IN UNIFORM LENGTHS OR SECTIONS.
3. PLACE 3/4" THICK PREMOLDED EXPANSION JOINT FILLER MATERIAL AT STRUCTURES AND AT THE END OF THE WORK DAY, CUT MATERIAL TO CONFORM TO AREA ADJACENT TO CURB OR TO CONFORM TO CROSS SECTIONAL AREA OF CURB.
4. WHERE CURBS ARE INSTALLED ADJACENT TO PARKING LANES A 6" HIGH CURB CAN BE UTILIZED WITH APPROVAL FROM THE LOCAL MUNICIPALITY.

HATFIELD BOROUGH
PLAIN CEMENT CONCRETE CURB
DETAIL

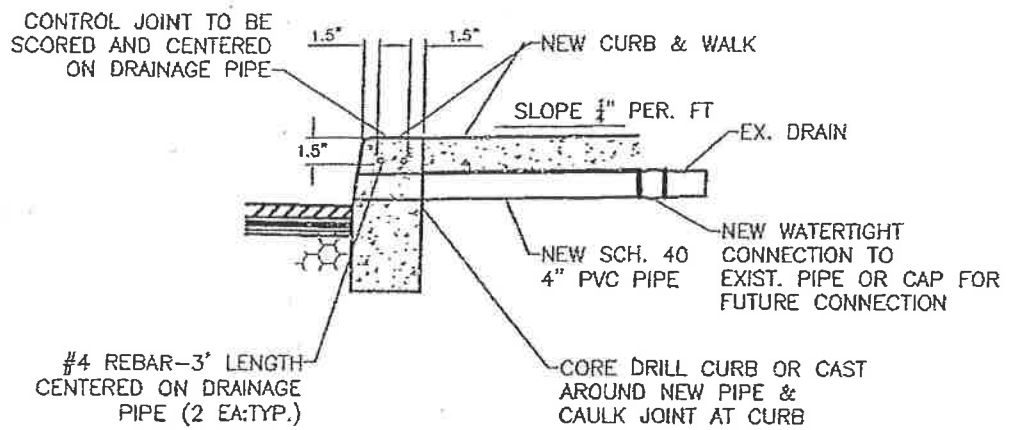

HATFIELD BOROUGH
 TYPICAL DRAIN THROUGH CURB
 DETAIL

