

DRIVEWAY PERMIT



Code Enforcement/Building/Zoning

401 S. Main Street, Hatfield, PA 19440

O: (215) 855-0781x108 F: (215) 855-2075

Code@HatfieldBorough.com

www.HatfieldBorough.com

DRIVEWAY PERMIT APPLICATION

Applicants shall submit two (2) legible copies of all drawings, plans, and construction documents. Commercial plans must be signed and sealed by a licensed design professional, while residential plans may also require signing and sealing depending on the complexity of the project. Permit applications involving the installation of new driveways or the extension of existing driveways must include a current property survey clearly indicating all existing and proposed improvements. A Professional Services Agreement may also be required at the discretion of the Borough Engineer or Borough Manager.

Permit # _____
Date <u> </u> / <u> </u> / <u> </u>
Fee \$ _____

PROPERTY

INFORMATION

Number _____	Street _____
--------------	--------------

OWNER INFORMATION

First Name _____	Last Name _____	Daytime Phone _____
Email Address _____		Cell Phone _____
Number _____	Street _____	City/Zip _____

CONTRACTOR INFORMATION

<input type="checkbox"/> Check if work is being completed by the Property Owner			
License #	Name Address	Phone/Email	Value

ENGINEER INFORMATION

License #	Name	Address	Phone/Email	Value

Existing Length by Width _____	Proposed Length by Width _____
Road Driveway Abuts _____	Does Curbing Exist _____
Minimum Curb Radius _____	Maximum Curb Radius _____
Proposed Surface Material _____	Time of Proposed Work _____
Dip Section Pipe and Construction Sizes and Types _____	

PROPOSED DRIVEWAY CHANGE

APPLICATION SUBMISSION DOES NOT GRANT APPROVAL TO START WORK

I agree to comply with all applicable codes, statutes and ordinances and with the conditions of this permit; I understand that the issuance of the permit creates no legal liability, express or implied, on Hatfield Borough; and certify that all the above information is accurate. Permit expires if work is not started in six (6) months, not completed in twelve (12) months, or if work is discontinued for six (6) months in the judgement of the Borough. The Building Inspector, or the Inspector's authorized agent, is authorized to enter the premises for which this permit is sought at all reasonable hours and for any *proper purpose* to inspect the proposed work. Failure to comply with the above will result in a STOP WORK ORDER.

Owner Authorized Name _____	Owner/Authorized Signature _____	Date _____
-----------------------------	----------------------------------	------------

DRIVEWAY PERMIT

SITE PLAN

A site plan must be provided for all applications. If you already have a site or plot plan, you may submit that plan instead of using the site plan below as long as all required information is included. Please be sure **to include the following information on the plan.**

Property dimensions

All existing buildings, decks/patios, sheds, pools, fences and driveways with dimensions

All proposed construction with dimensions

Distances from all property lines to proposed construction

Distances between existing buildings and proposed construction

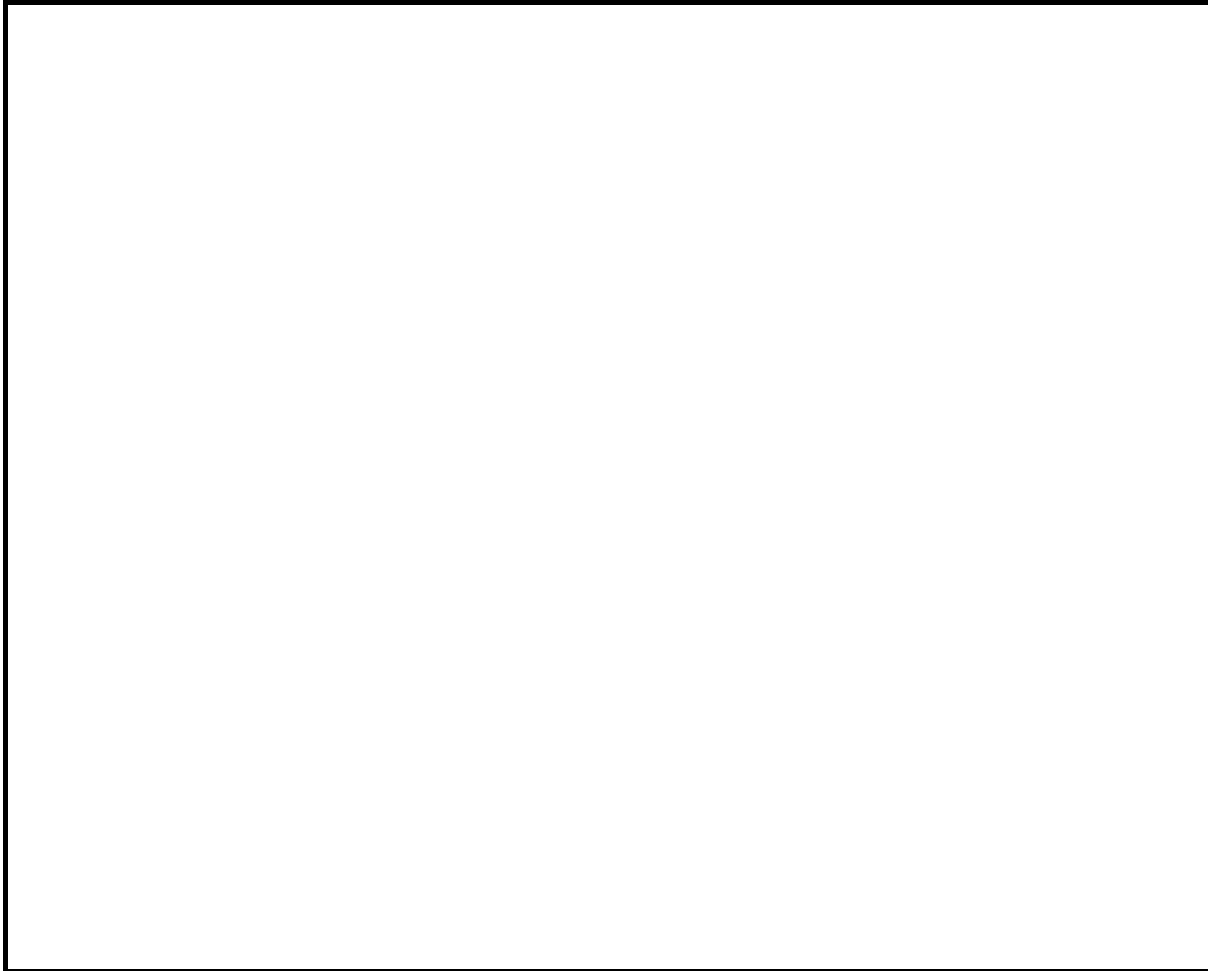

Site Plan or Plot Plan used in place of this page **JO Additional pages included with Application**

FOR HATFIELD BOROUGH USE ONLY

Zoning Permit Fee	\$	PA State Act 13 Fee	\$4.50
Application Fee	\$150.00	TOTAL OF ALL FEES	\$

Zoning Officer

Date

DRIVEWAY PERMIT

DRIVEWAY PERMIT INFORMATION

After the Driveway Permit Application is submitted and the initial \$150 permit fee is paid, the Driveway Permit Application is reviewed by the Borough Engineer. This may take several days to a couple weeks. The Borough Engineer, at his convenience, may schedule to meet the applicant at the site of the application. The applicant or a representative of the applicant would have to meet the Borough Engineer at the proposed driveway site in case there are any questions on the submitted Driveway Permit Application. The Borough Engineer will reach out to the applicant if the need for a site visit is required.

After inspecting the proposed driveway site, the Borough Engineer may determine that additional conditions may be needed, which will then be added to the Driveway Permit Application. Several days to a couple weeks shall be allowed for processing of the application.

The Zoning Department will contact the applicant when the Permit has been processed, and is ready to be paid for and picked up. There will be additional Permit Fees based on the size of the driveway extension.

Submitted with the Driveway Permit Application should be any documents and drawings that show the outlines of the property and it's existing conditions included but not limited to driveways, walkways, drains and culverts, the proposed changes including any driveways, walkways, drains or culverts, and the relationship of the property and the proposed changes to the Borough Street.

The Driveway Permit is good for one (1) year after the date of issuance. If an extension is needed, the Borough must be notified in writing.

GENERAL REGULATIONS

1. Paved driveways shall consist of 2" depth bituminous wearing course on 4" depth 2A modified stone base.
2. The property owner is responsible for obtaining any other permits which may be required and complying with any other State or Federal Government regulations.
3. The slope of the driveway shall not exceed twelve (12) percent. The first twenty feet from the curblines shall not exceed five (5) percent.
4. A driveway serving a single dwelling unit shall have a minimum width of ten (10) feet. A common driveway, serving up to four (4) dwelling units shall have a minimum width of sixteen (16) feet.
5. A driveway serving a single dwelling unit shall be located as far from street intersections as reasonably possible, but no less than fifty (50) feet from the nearest street intersection.
6. The construction of all driveways will be subject to the inspection and approval of the Borough. The Borough shall be notified a minimum of forty-eight (48) hours in advance of construction.
7. Concrete aprons for driveways shall be six (6) inches thick and reinforced with six (6) by six (6) inch number nine (9) wire. The wire shall be installed no closer than 1/2 inch from the top or bottom surfaces of the apron.
8. Curbing
 - a) The permit may require the installation of curbing wherever it is required to control access and/or drainage. All curbing must be permanent curbing.
 - b) Where property abutting the road right of way line could be used as a parking area, the permit may require curbing, permanent guiderail or fencing to be constructed along the right of way line in order to prohibit vehicle encroachment upon the sidewalk or shoulder area
 - c) When curb exists adjacent to the proposed driveway, the line and grade of the existing curb shall be matched, unless otherwise authorized by the permit.

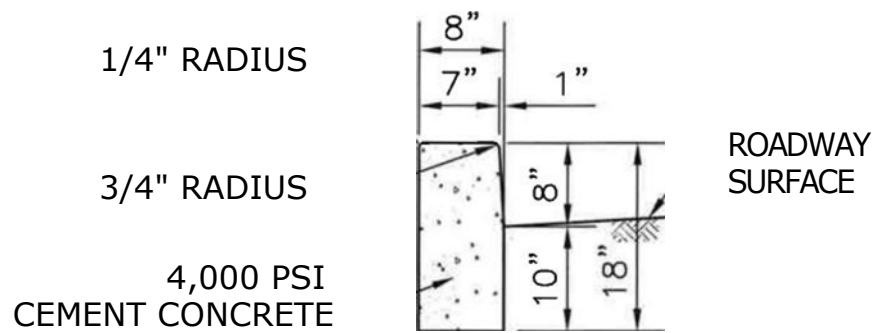
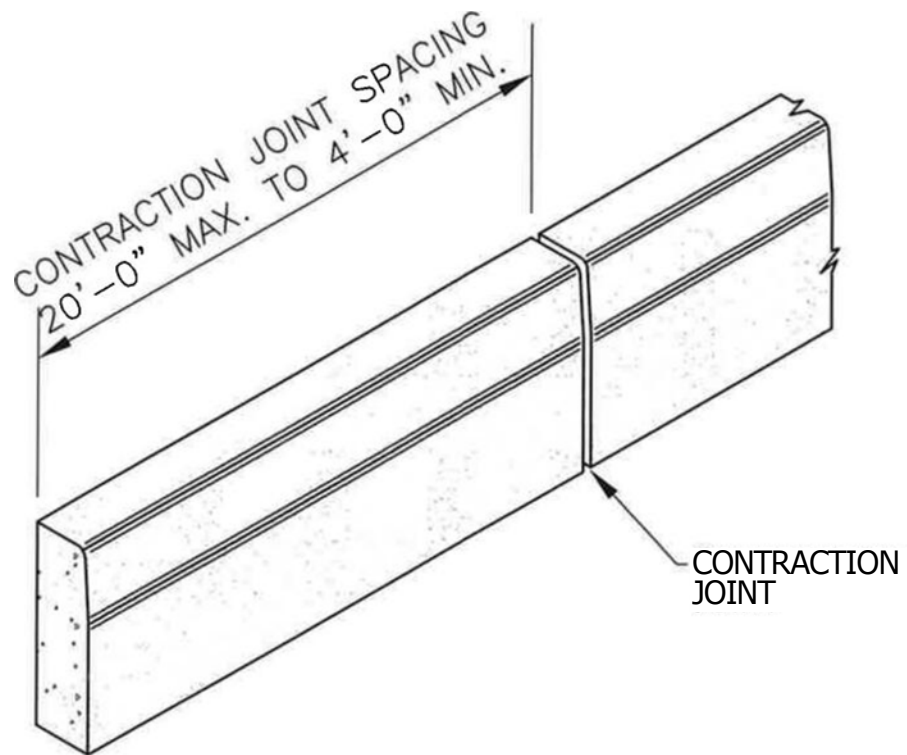

NOTES:

1. IF CURB IS BEING REPLACED, MATCH HEIGHT OF EXISTING CURB ON EACH END.

HATFIELD BOROUGH
CONCRETE CURB DETAIL

NO SCALE

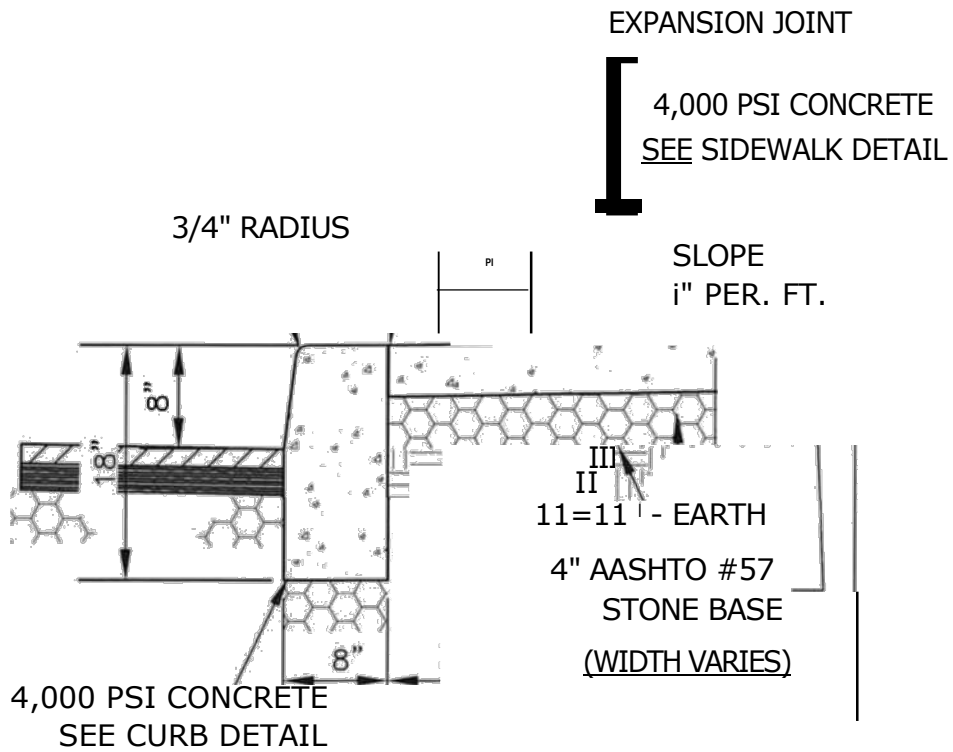

HATFIELD BOROUGH STRAIGHT
CURB & SIDEWALK DETAIL

NO SCALE

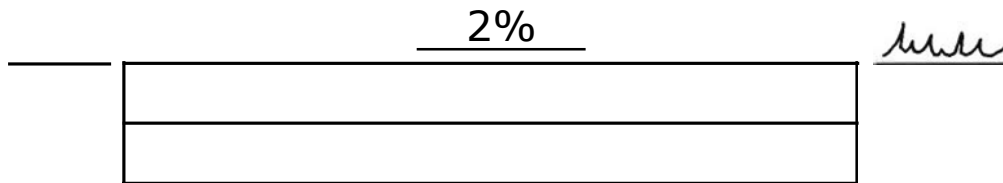

4" AIR-ENTRAINED CONCRETE
(MIN. 4,000 PSI)

4" AASHTO #57 STONE

SIDEWALK DETAIL NOTES:

1. SIDEWALKS AT DRIVEWAYS SHALL BE 6" THICK CONCRETE WITH 6"x6" - NO. 9 WIRE (2 LAYERS, 2" APART. 1" FROM SURFACE.)
0. 4" BIT. EXP. JOINT AT 20' O.C.
- 3 CONSTRUCTION JOINT AT 5' O.C.

HATFIELD BOROUGH SIDEWALK/DRIVEWAY APRON DETAIL

NO SCALE

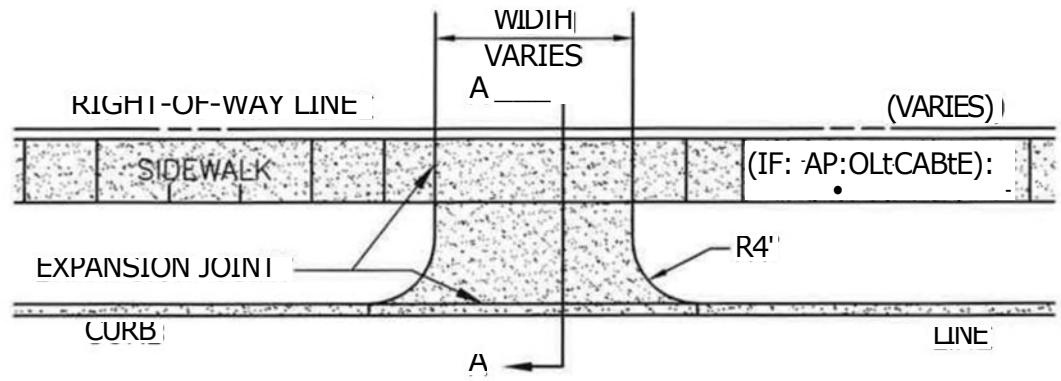
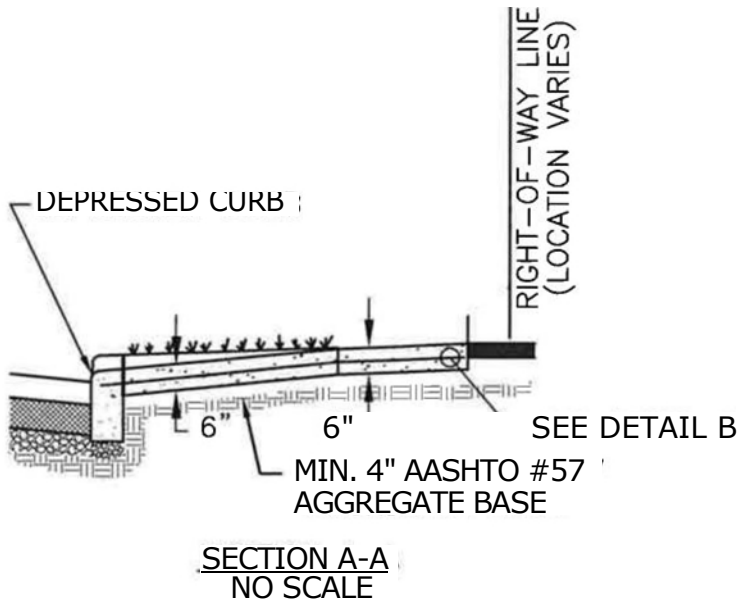
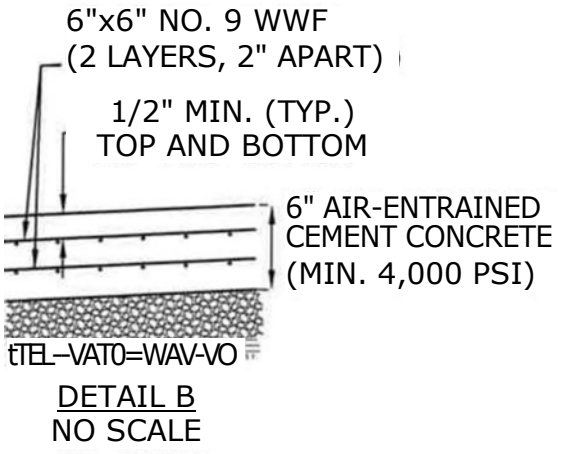

**HATFIELD BOROUGH
DRIVEWAY APRON DETAIL
WITH GRASS STRIP**

NO SCALE

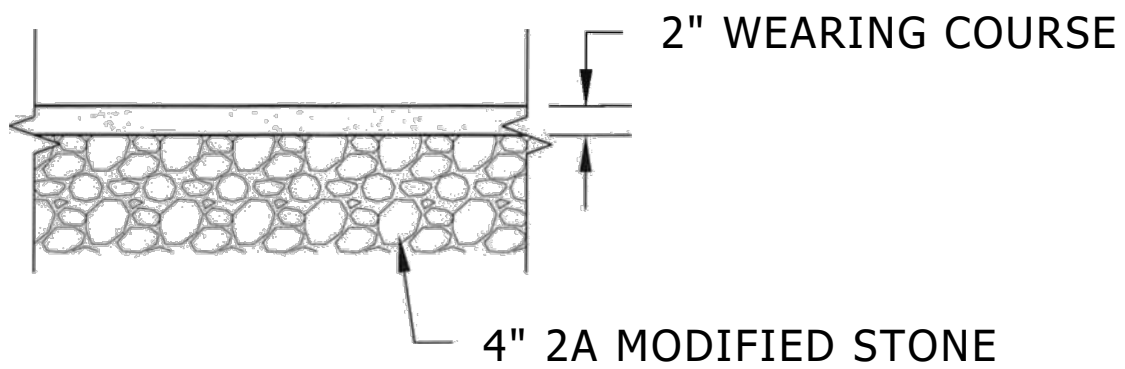

HATFIELD BOROUGH
TYPICAL DRIVEWAY PAVING DETAIL
NO SCALE